

# Blackline F10

Compact two-way passive system

## features

- ▶ Compact two-way passive system
- ▶ Multi-angle birch ply enclosure
- ▶ User rotatable 90° x 50° horn
- ▶ High power output
- ▶ Flexible mounting options
- ▶ Five year limited warranty

## applications

- ▶ Club sound reinforcement
- ▶ Unobtrusive stage monitoring
- ▶ Fill-in system for main PA
- ▶ AV presentations



professional

The Blackline F10 is a versatile, 2-way passive system, designed to provide exceptional sound reinforcement and stage monitoring from a very compact enclosure. It features a powerful 10" (250mm) low frequency driver and a 1" (25mm) HF compression driver mounted on a constant directivity 90° x 50° horn. Depending on the application, the HF horn can be rotated to allow the multi-angle enclosure to be used in either its vertical or horizontal orientation.

The 2-way passive design of the F10 enables simple, high performance systems to be put together whilst minimising the number of amplifier channels required. Where extra low frequency is required, sub-bass systems such as the Blackline S12, S15 or S18 may be added.

The enclosure is provided with ten M8 inserts and four M8 inserts for a variety of mounting arrangements. It is also provided with a top hat fitting for use with a tripod or as a pole socket for mounting above the Blackline subwoofer.

Use of a controller with the F10 is optional. For demanding applications, an M3 or DXI controller configured to perform EQ and limiter functions is recommended.

Century Point, Halifax Road, Cressex Business Park,  
High Wycombe, Buckinghamshire HP12 3SL, England.  
Telephone: +44 (0)1494 535312 Facsimile: +44 (0)1494 438669  
E-mail: [info@martin-audio.com](mailto:info@martin-audio.com)  
All information is Copyright © 2003 Martin Audio Ltd.



# Blackline F10

Compact two-way passive system

polar plots

professional

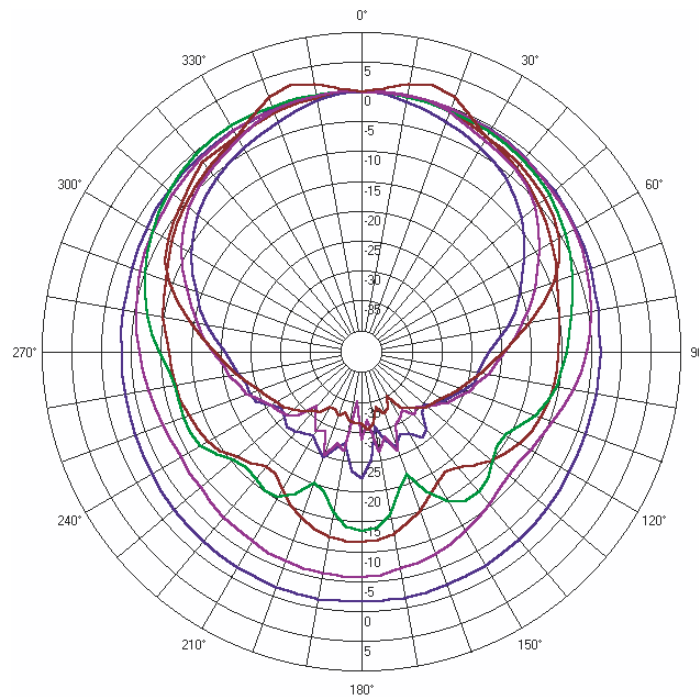
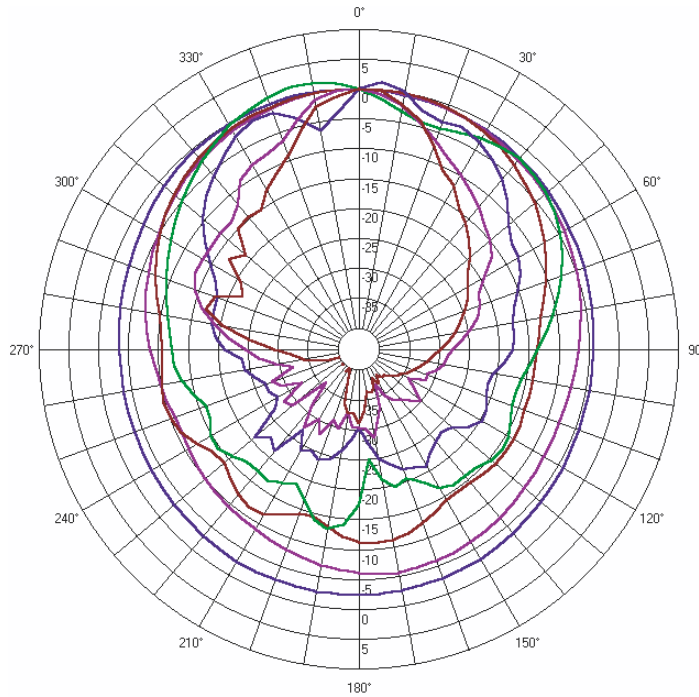

Century Point, Halifax Road, Cressex Business Park,  
High Wycombe, Buckinghamshire HP12 3SL, England.  
Telephone: +44 (0)1494 535312 Facsimile: +44 (0)1494 438669  
E-mail: [info@martin-audio.com](mailto:info@martin-audio.com)  
All information is Copyright © 2003 Martin Audio Ltd.



# Blackline F10

Compact two-way passive system

frequency responses

professional

F10 Horizontal Magnitude in dB SPL/2.83V at 1 meter

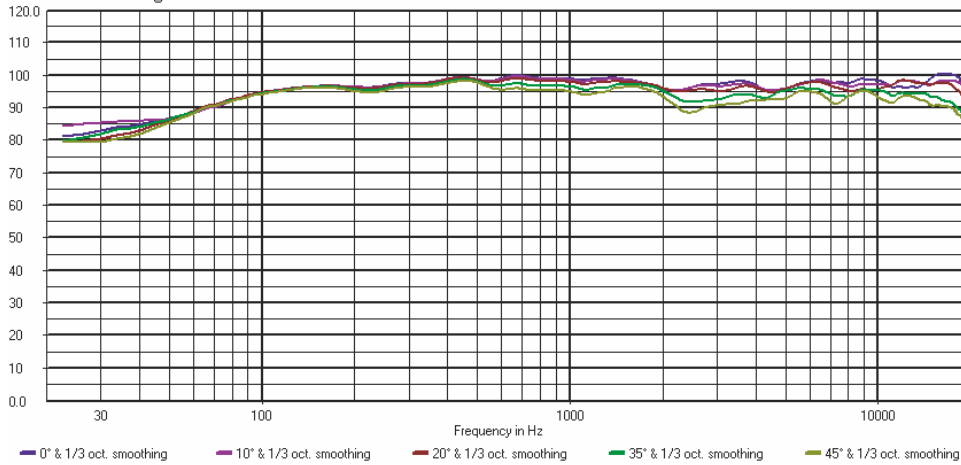

F10 Horizontal Beamwidth

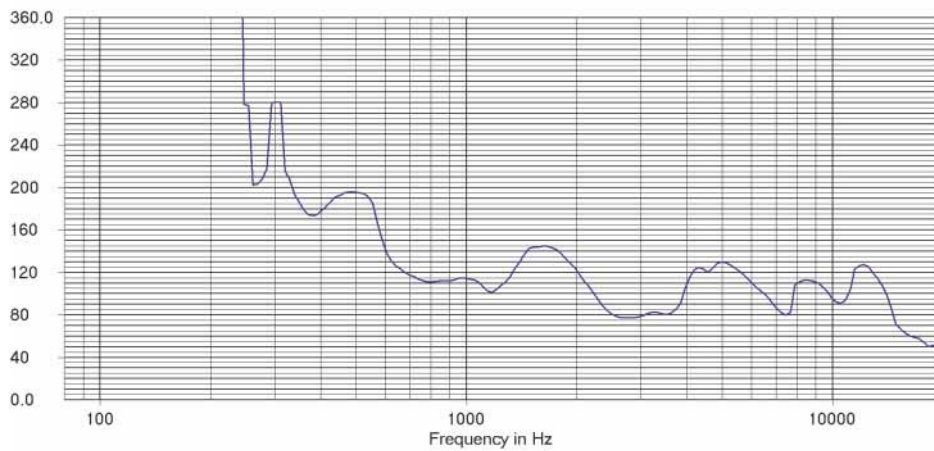

F10 Vertical Beamwidth

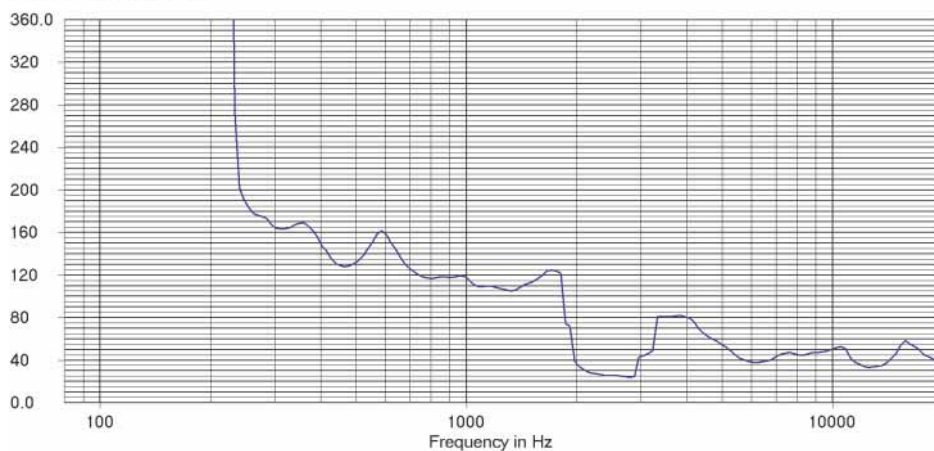

Century Point, Halifax Road, Cressex Business Park,  
High Wycombe, Buckinghamshire HP12 3SL, England.  
Telephone: +44 (0)1494 535312 Facsimile: +44 (0)1494 438669  
E-mail: [info@martin-audio.com](mailto:info@martin-audio.com)  
All information is Copyright © 2003 Martin Audio Ltd.



# Blackline F10

Compact two-way passive system

overall dimensions

professional

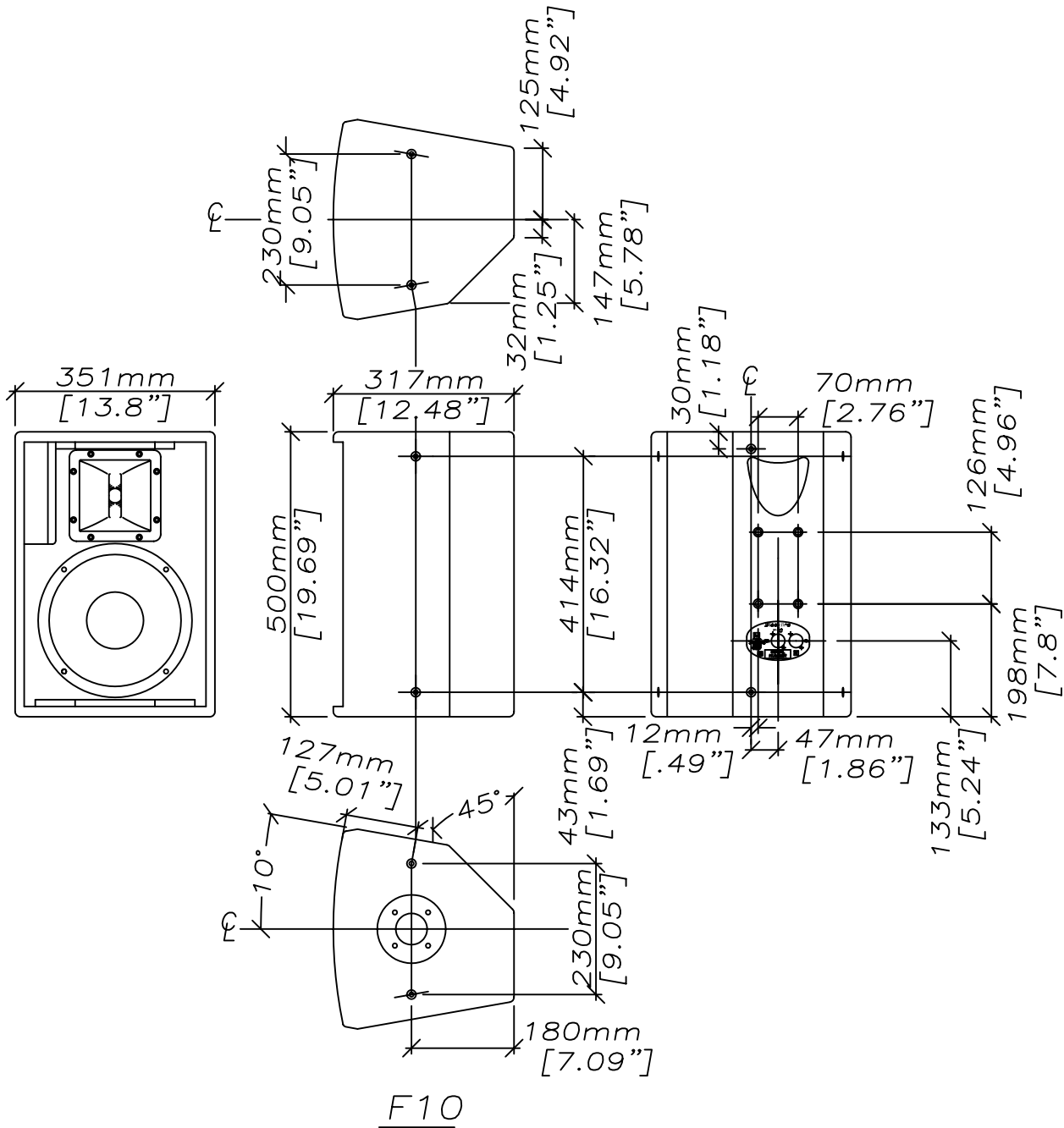

Century Point, Halifax Road, Cressex Business Park,  
High Wycombe, Buckinghamshire HP12 3SL, England.  
Telephone: +44 (0)1494 535312 Facsimile: +44 (0)1494 438669  
E-mail: [info@martin-audio.com](mailto:info@martin-audio.com)  
All information is Copyright © 2003 Martin Audio Ltd.



# Blackline F10

Compact two-way passive system

professional

## technical specifications

TYPE	Compact, two-way passive
FREQUENCY RESPONSE (1)	65Hz-20kHz $\pm$ 3dB
LOW FREQUENCY LIMIT	56Hz (-10dB)
DRIVERS	1 x 10" (250mm)/2.5" (63mm) voice coil LF driver 1 x 1" (25mm) exit HF compression driver
RATED POWER (2)	300W AES, 1200W peak
RECOMMENDED AMPLIFIER	400-650W into 4 ohms
SENSITIVITY (3)	96dB
MAXIMUM SPL (4)	119dB continuous, 125dB peak
IMPEDANCE	8 ohms nominal
DISPERSION (-6dB)	90°H x 50°V
CROSSOVER	2kHz passive
ENCLOSURE	23 litre (0.8 cu foot) vented, multi-laminate birch ply
FINISH	Textured black paint
PROTECTIVE GRILLE	Black perforated steel
CONNECTORS	2 x Neutrik Speakon NL4
FITTINGS	10 x M8 threaded inserts, 1 x top hat fitting 4 x M8 inserts for HTKM20 wall bracket
DIMENSIONS	(W) 351mm x (H) 500mm x (D) 317mm (W) 13.8ins x (H) 19.7ins x (D) 12.5ins
WEIGHT	17kg (37lbs)

## accessories

HTKCT04	Pole
HTKCT05	8mm Shouldered Eye Bolt
HTKFI0Y	Flying Yoke
HTKM20	Wall Bracket (supplied in pairs)
COVF10	Black Padded Cover

### Notes

- (1) Measured on-axis in half space at 2 metres, then referred to 1 metre.
- (2) AES Standard ANSI S4.26-1984.
- (3) Measured in half space conditions at 2 metres with 1 watt input, using band limited pink noise, then referred to 1 metre.
- (4) Measured in half space conditions at 2 metres using band limited pink noise, then referred to 1 metre.

### Trade Descriptions Act

Due to Martin Audio's policy of continuing improvement, we reserve the right to alter these specifications without prior notice. Martin Audio is committed to refining state of the art sound reinforcement, combining in-depth product and field applications research with advanced manufacturing techniques. Every Martin Audio product is built to the highest manufacturing standards and rigorously tested to ensure that it meets the performance criteria specified in the design.

## architectural and engineering specifications

The loudspeaker system shall be of the two-way passive type consisting of one 10" (250mm) direct radiating reflex loaded low frequency transducer and one 1" (25mm) exit HF compression driver mounted on a user rotatable constant directivity horn in a multi-angled enclosure. The enclosure shall be of a multi-laminate birch ply construction with integral pole mount and threaded inserts for wall and ceiling mounting. Low and high frequency sections shall be integrated by an internal 2kHz passive crossover network.

Performance of the loudspeaker system with its electronic controller shall meet or exceed the following criteria:

Frequency response measured 1 metre on axis shall be 65Hz-20kHz  $\pm$  3dB.

High frequency dispersion at -6dB points shall be 90°H x 50°V.

Power handling shall be 300W AES, 1200W peak.

Rated impedance shall be 8 ohms.

Maximum SPL measured at 1 metre on axis shall be 119dB continuous, 125dB peak.

Dimensions (W) 351mm x (H) 500mm x (D) 317mm (13.8ins x 19.7ins x 12.5ins).

Weight 17kg (37lbs).

The loudspeaker system shall be the Martin Audio F10.

Century Point, Halifax Road, Cressex Business Park,  
High Wycombe, Buckinghamshire HP12 3SL, England.  
Telephone: +44 (0)1494 535312 Facsimile: +44 (0)1494 438669  
E-mail: [info@martin-audio.com](mailto:info@martin-audio.com)  
All information is Copyright © 2003 Martin Audio Ltd.

